

Skyhook Rooftop Anchors:

Attachment Methods:

- #14x10 2" self drill fasteners. Qty. 30 fasteners provided with each anchor.

Anchorage Requirements:

- 3/4" CDX Plywood Roofing
- 20ga. Metal decking or thicker

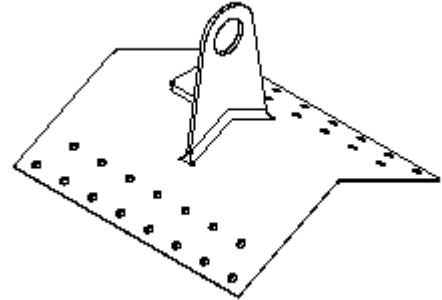

System Features:

- Designed for installation at the peak of qualified roof structures.
- Individual Skyhook can be used for 1 person in fall arrest or fall restraint.
- Powder coated durable finish
- Separate flashing kit available

Can Facilitate a Catenary Horizontal Line System:

For Low Slope Roofs 4/12 pitch or less:

Up to 4 workers per continuous run of cable with anchors spaced no more than 16ft. o.c.

For Steep Slope Roofs 5/12 or steeper:

1 worker in fall arrest per continuous run of cable with anchors spaced no more than 16ft. o.c.



Skyhook Roof Anchors

WILL IT FIT ANY PITCH?

No. You must reference the chart on this page to order the correct anchor for your roof pitch.

HOW MANY WORKERS CAN I ATTACH?

If you install the anchors without the cable catenary line system, you can attach one worker to each anchor.

With the catenary line system, you can attach up to 4 workers if you are set up in a FALL RESTRAINT system.

CAN I REUSE THE SKYHOOK?

Yes. As long as you do not damage the Skyhook when removing it, although the Guardian TEMPER anchor will work better for temporary uses.



26513 79th Ave. S.
Kent, WA
800-466-6385
www.guardianfall.com

APPLICATIONS:

For use on commercial or residential roof tops.

Wood Decking ¾" CDX Plywood or better

Metal Decking 20ga. and thicker

Concrete (2000p.s.i. minimum)

* Fasteners available separately

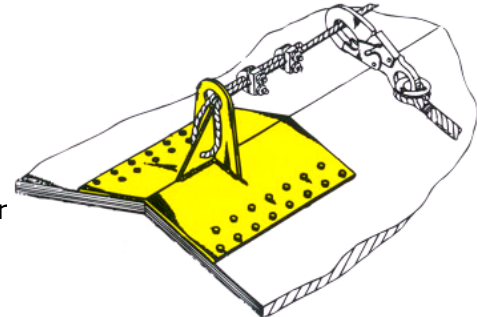

FEATURES:

Powder coated for durability

Can facilitate horizontal lifeline systems for multiple workers

ROOF PITCH CHART:

MODEL #	SIZE	ROOF PITCH
00300	SH-00	Flat Pitch Roofs
00310	SH-03	1/12 through 3/12
00320	SH-06	4/12 through 6/12
00330	SH-09	7/12 through 9/12
00340	SH-12	10/12 through 12/12

INSTALLATION AND PROPER USE:

Install Skyhook Anchors at the peak of a roof meeting the above required substrate thickness. Maximum recommended spacing is 16ft. apart along the ridge line. Use #14x10 2" screws to fill the holes in the Skyhook. Screws may be purchased from Guardian as a separate item.

One worker per anchor, maximum worker weight is 310lbs. When on a low slope (4/12 or less pitch) a cable catenary line system can be used to allow up to 4 workers to tie-off in FALL RESTRAINT.

MULTI USER CATENARY LINE SYSTEMS:

When Skyhooks are spaced a maximum of 16ft. apart, they can be used to facilitate a cable catenary line, allowing up to 4 workers to tie-off in FALL RESTRAINT (or one in FALL ARREST) per run of unterminated catenary cable.

Attach 3/8" galvanized aircraft cable (14,400 tensile strength min.) through the hole at the top of the Skyhook, go through the gusset hole on the back of the anchor, and bring the cable back through the large hole at the top, reattaching the cable to itself using approved cable clamps. Run the cable between a series of Skyhook anchors, passing through the intermediate large Skyhook holes and terminating at the end of the desired run length.

Do not stretch the cable tight! Allow 18" of slack in the total length of the cable. For more information on FALL RESTRAINT consult OSHA or contact Guardian for additional information.

Skyhook is tested to meet all applicable ANSI Z359.1 standards and comply with OSHA standards. Use only with compatible equipment.

SECTION 11500 - INDUSTRIAL SAFETY**PART 1 - GENERAL****1.1 SUMMARY**

- A. Section Includes: Steel roof top tie-down for worker safety. Type: SKYHOOK (Fall Arrest/Fall Restraint system).
- B. Related Sections:
 - 1. Section 06100-Rough Carpentry
 - 2. Section 07600-Flashing and Sheet Metal
 - 3. Section 01500-Temporary Facilities (Industrial Safety – Cables, harnesses & anchors)

1.2 REFERENCES AND DEFINITIONS

- A. Occupational Safety and Health Standards (OSHA) for the Construction Industry 29 CFR § 1926.500 Subpart M through § 1926 Subpart M, Appendix E.
- B. WAC 296-155-2401 through 296-155-24525, Part C-1, Fall Restraint and Fall Arrest (WISHA).
- C. ASTM A446 Sheet Steel, Zinc Coated (Galvanized) by the Hot-Dip Process, Structural (Physical) Quality.
- D. ASTM A36/A36M-01 Hot-Rolled Carbon Steel Sheets and Strip, Structural Quality.

1.3 SYSTEM DESCRIPTION

- A. General: Provide fall arrest for one person on steep sloped roofs and fall restraint for up to four persons on low sloped roofs when used in accordance with manufacturer's recommendations and specifications.
- B. Design Requirements: The steel tie-down shall be designed to be a permanent fixture attached to the roof structure. The system shall allow any workman to perform any task needed, such as roof covering application, roof maintenance, or any other roof top work, without fear of injury. Contractor shall verify compatibility of other safety components to be used to comply with OSHA/ANSI requirements (See 01500).

1.4 SUBMITTALS

- A. Product Data: Submit manufacturer's product data, installation instructions, and material description. Submit test reports.
- B. Shop Drawings: Show layout, details and anchorage. Submit engineering calculations. Submit fasteners and fastener test data.

PART 2 - PRODUCTS**2.1 MANUFACTURER AND PRODUCT NAME**

- A. Guardian Fall Protection, Inc., 26513 79th Ave S., Kent, WA 98032 (Local phone: (253) 854-5877, fax: 253-854-5980. Out-of-State phone: 800-466-6385, fax: 800-670-7892)
- B. Or other approved equal complying with OSHA, ANSI, WISHA, fall arrest, and fall restraint systems.

2.2 MATERIALS

- A. Steel Eyelet: ASTM A570 3/16" structural plate ([powder coated MIL-PRF-24712 type IV] [galvanized (2.0 oz./sq. ft.)])¹ after fabrication.
- B. Steel Plate: ASTM A570, G165, 11 ga [powder coated MIL-PRF-24712] [galvanized (2.0 oz./sq. ft.)]
- C. Accessories: Fasteners by Illinois Tool Works, Inc. (itw) Buildex, Rawl or approved equal.

2.3 FABRICATION

- A. Description: 3/16" steel tie-down eyelet and welded to 1/8" (11 ga.) steel plate contoured to roof shape and slope powder coated (MIL-PRF-24712 type IV) after fabrication.
- B. Roof Slope:²

PART 3 - EXECUTION**3.1 EXAMINATION**

- A. Examine framing and roof surface for adequacy and compliance with structural requirements of this system design.
- B. Notify Architect/Engineer of any defects or improper coordination prior to commencing work.

3.2 INSTALLATION

- A. Anchorage:³ Secure roof top tie down plate to structural plywood deck with 30 #14 x 1-1/2" wood screws driven into plywood to protrude 1/4" below plywood.
- B. Anchorage:⁴ Secure roof top tie down to sheet metal roofing with 30 #5 self drilling fasteners or 30 #14 x 3/4" stitch TEK fasteners.
- C. Anchorage:⁵ Secure roof top tie down to concrete or steel surface using adequate number of 1/4" fasteners to attain 18,000 lbs. holding or pull out on base plate (see local fastener outlet).

END OF SECTION

¹ Edit for galvanized. Rev. 12/7/92 rdm² Specify roof slope. Rev. 12/7/92 rdm³ 5/8" exterior plywood roof sheathing. If less than 5/8", requires 2x4 blocking or 3/4" CDX plywood backing between supports.⁴ 20 ga. Sheet metal min. roofing. If other, requires 3/4" wood blocking between supports.⁵ 2000 lb. p.s.i. tensile strength concrete minimum.

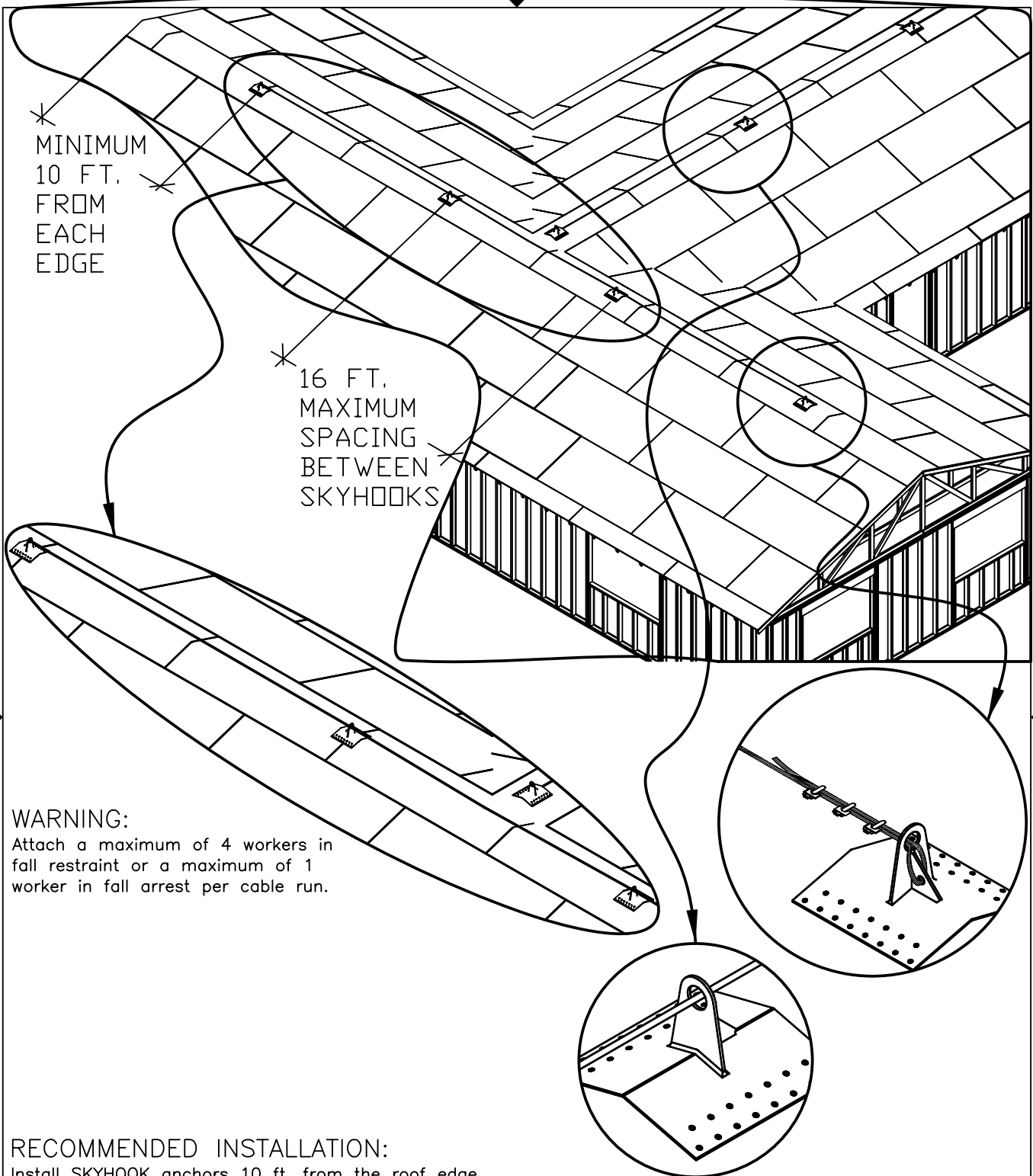

MINIMUM
10 FT.
FROM
EACH
EDGE

16 FT.
MAXIMUM
SPACING
BETWEEN
SKYHOOKS

WARNING:

Attach a maximum of 4 workers in fall restraint or a maximum of 1 worker in fall arrest per cable run.

RECOMMENDED INSTALLATION:

Install SKYHOOK anchors 10 ft. from the roof edge and space them a maximum of 16 ft. apart.

INSTALLATION INSTRUCTIONS			TITLE SKYHOOK RECOMMENDED LAYOUT INFORMATION			
DESIGNED BY:	B. WOODYARD	1992	DWG NO.			
DRAWN BY:	PHIL GOMES	09/08/2004	SCALE: NONE		SHEET: 1	
CHECKED BY:	MATT VOLLMER	04/15/2005				
APPD BY:	MATT VOLLMER	04/15/2005				

REVISIONS

ZONE	REV	DESCRIPTION	DATE	APPROVED
------	-----	-------------	------	----------

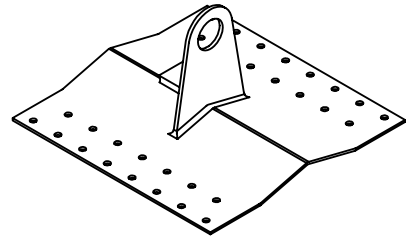

3D VIEW

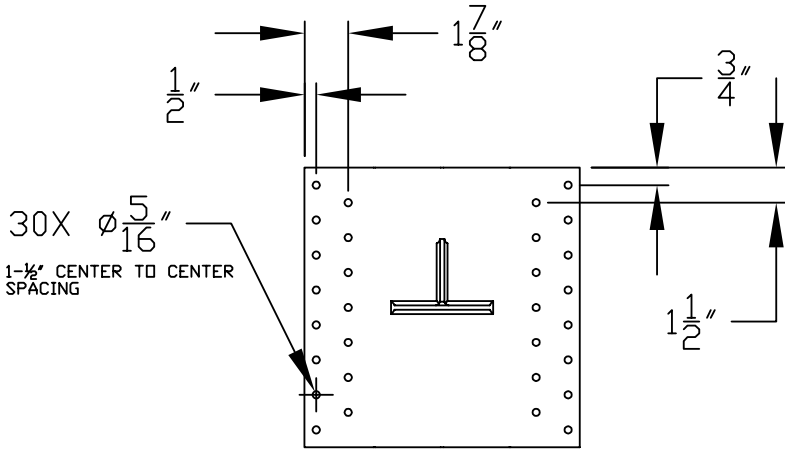

PLAN VIEW

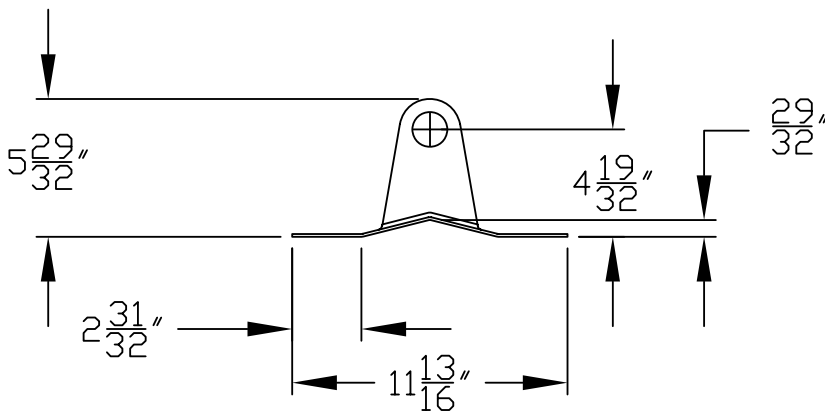

FRONT VIEW

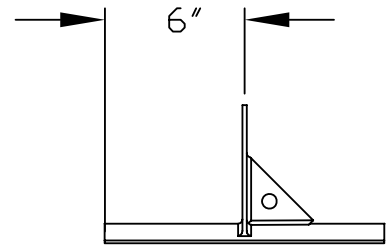

SIDE VIEW

TOLERANCES: .XXX .XX .X ANGLES $\pm .003$ $\pm .06$ $\pm .1$ $\pm \frac{1}{4}$		TREAT: NONE	FINISH: NONE	TITLE SKYHOOK ROOF ANCHOR FLAT		
DESIGNED BY: B. WOODYARD	1992			DWG NO. SH-00		
DRAWN BY: PHIL GOMES	10/29/2004			SCALE: 1:8	SHEET: SHT #	
CHECKED BY: MATT VOLLMER	10/29/2004					
APPD BY: MATT VOLLMER	10/29/2004					

REVISIONS				
ZONE	REV	DESCRIPTION	DATE	APPROVED

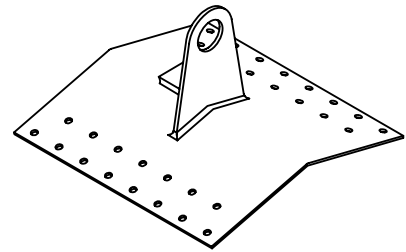

3D VIEW

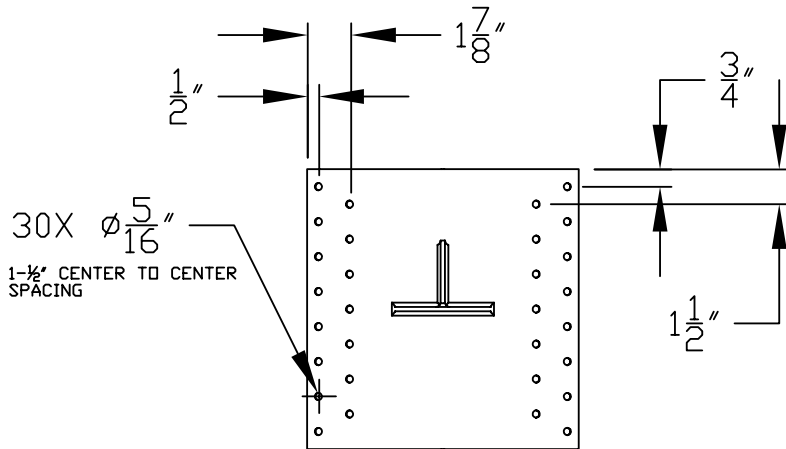

PLAN VIEW

DIMENSIONS SHOWN APPLY TO ACTUAL CENTER LINE LOCATION OF HOLES.

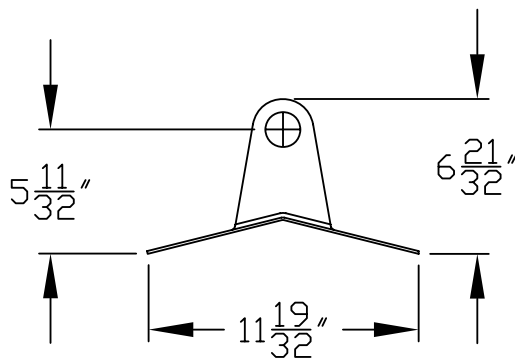

FRONT VIEW

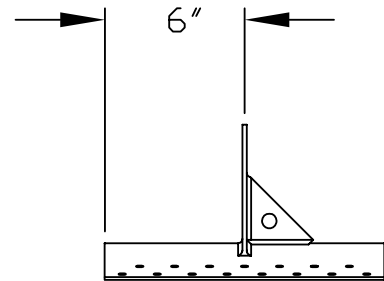

SIDE VIEW

TOLERANCES: .XXX .XX .X ANGLES $\pm .003$ $\pm .06$ $\pm .1$ $\pm \frac{1}{4}$		TREAT: NONE	FINISH: NONE <input checked="" type="checkbox"/>	TITLE SKYHOOK ROOF ANCHOR 1/12 TO 3/12		
DESIGNED BY: B. WOODYARD	1992			DWG NO. SH-03		
DRAWN BY: PHIL GOMES	11/02/2004			SCALE: 1:8	SHEET: 1	
CHECKED BY: MATT VOLLMER	11/02/2004					
APPD BY: MATT VOLLMER	11/02/2004					

REVISIONS				
ZONE	REV	DESCRIPTION	DATE	APPROVED

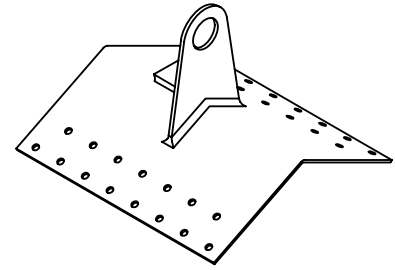

3D VIEW

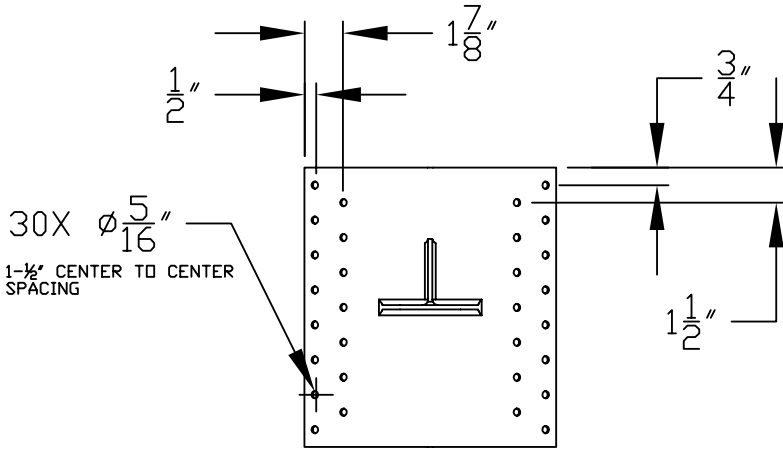

PLAN VIEW

DIMENSIONS SHOWN APPLY TO ACTUAL CENTER LINE LOCATION OF HOLES.

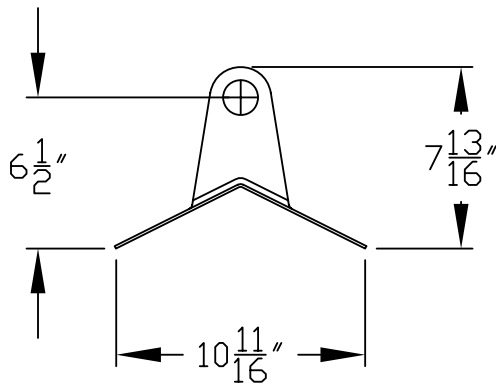

FRONT VIEW

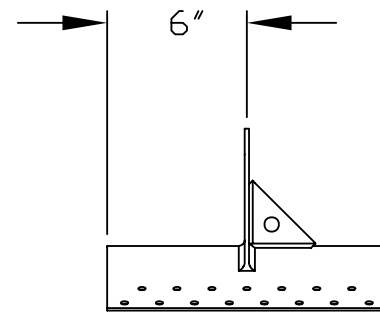

SIDE VIEW

TOLERANCES: $\begin{matrix} .XXX & .XX & .X \\ \pm .003 & \pm .06 & \pm .1 \end{matrix}$		TREAT: NONE	FINISH: NONE <input checked="" type="checkbox"/>	TITLE SKYHOOK ROOF ANCHOR 4/12 TO 6/12			
DESIGNED BY:	B. WOODYARD	1992	DWG NO.		SIZE	REV	
DRAWN BY:	PHIL GOMES	11/02/2004	SH-06		A	NEW	
CHECKED BY:	MATT VOLLMER	11/02/2004	SCALE: 1:8		SHEET: 1		
APPD BY:	MATT VOLLMER	11/02/2004					

REVISIONS

ZONE	REV	DESCRIPTION	DATE	APPROVED
------	-----	-------------	------	----------

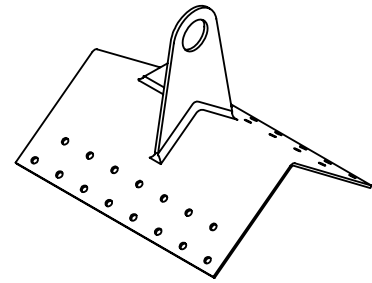

3D VIEW

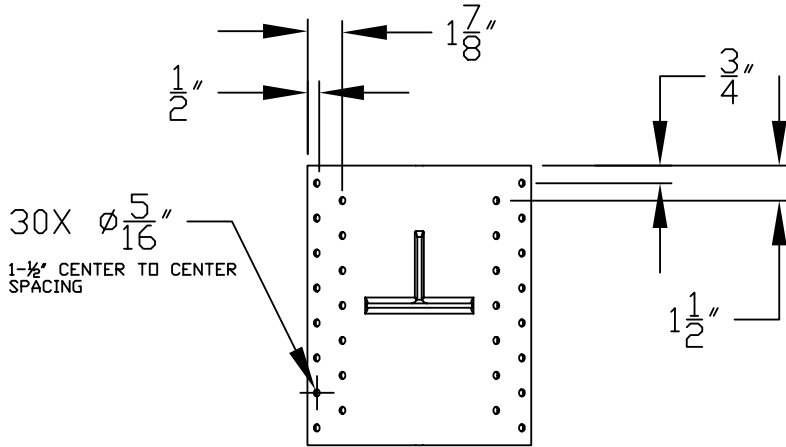

PLAN VIEW

DIMENSIONS SHOWN APPLY TO ACTUAL CENTER LINE LOCATION OF HOLES.

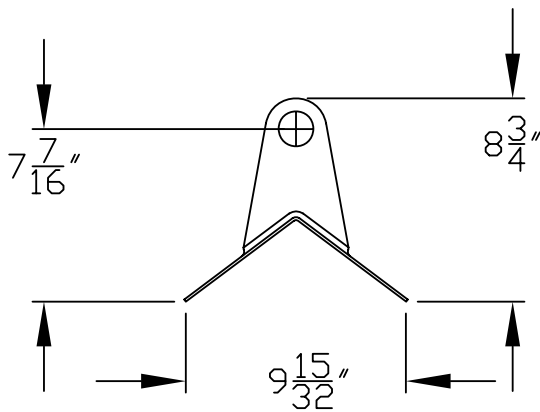

FRONT VIEW

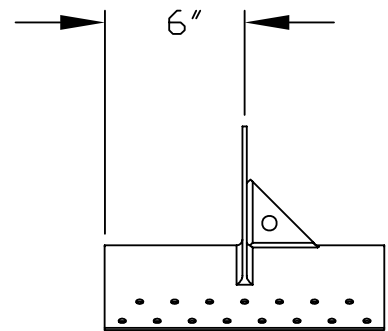

SIDE VIEW

TOLERANCES: .XXX .XX .X ANGLES ± .003 ± .06 ± .1 ± 1/4		TREAT: NONE	FINISH: NONE	TITLE SKYHOOK ROOF ANCHOR 7/12 TO 9/12		
DESIGNED BY: B. WOODYARD	1992			DWG NO. SH-09		
DRAWN BY: PHIL GOMES	11/02/2004			SCALE: 1:8	SHEET: 1	
CHECKED BY: MATT VOLLMER	11/02/2004					
APPD BY: MATT VOLLMER	11/02/2004					

REVISIONS

ZONE	REV	DESCRIPTION	DATE	APPROVED
------	-----	-------------	------	----------

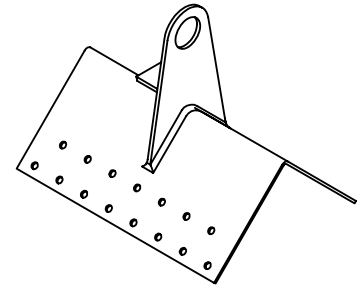

3D VIEW

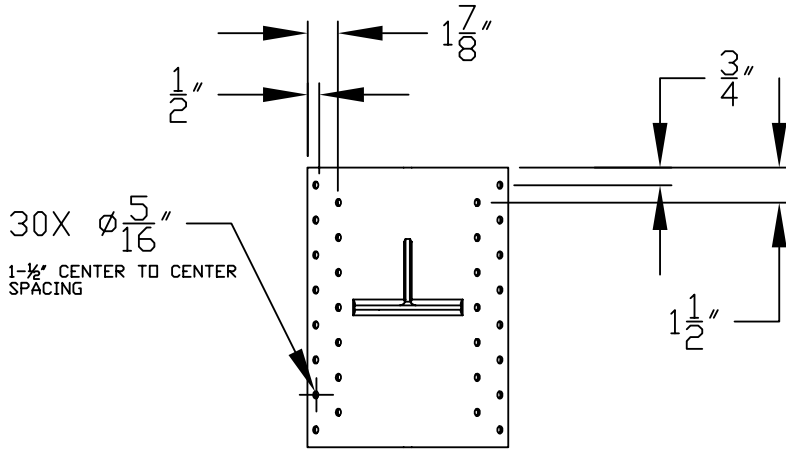

PLAN VIEW

DIMENSIONS SHOWN APPLY TO ACTUAL CENTER LINE LOCATION OF HOLES.

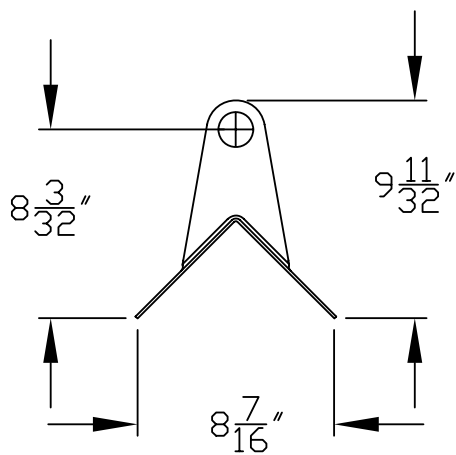

FRONT VIEW

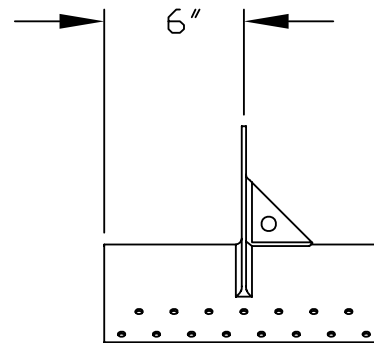

SIDE VIEW

TOLERANCES: .XXX .XX .X ANGLES ± .003 ± .06 ± .1 ± 1/4		TREAT: NONE	FINISH: NONE	TITLE SKYHOOK ROOF ANCHOR 10/12 TO 12/12		
DESIGNED BY: B. WOODYARD	1992			DWG NO. SH-12		
DRAWN BY: PHIL GOMES	11/02/2004			SCALE: 1:8	SHEET: 1	
CHECKED BY: MATT VOLLMER	11/02/2004					
APPD BY: MATT VOLLMER	11/02/2004					

JUN 17 '92 07:53AM AME 907 376 9197

AME ENGINEERS, INC.

P.O. BOX 871430
WASILLA, ALASKA 99687

(907) 376-1090
(907) 376-9197 FAX

DATE: June 16, 1992

TO: Guardian Metal Products
911 12TH Street S.E.
Auburn, Washington 98002

ATTN: Bud Woodyard

SUBJ: Roof Arrest System

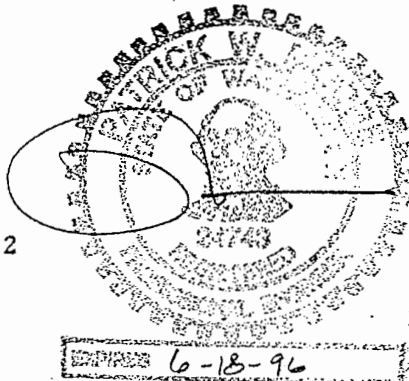

We have investigated the above noted system in accordance with Part C-1 WAC 296-155 FALL RESTRAINT AND FALL ARREST. We have enclosed our calculations supporting our findings and design conforms to the 5000 pound requirements noted in Wac 296-155-24510 3-a (vii). We understand that this unit will be built for a variety of roof slopes, although the slope of the roof will not effect the values given for hold-down capacities noted here-in.

This unit is intended to be utilized with both steel and wood construction and will be attached with various screw types. Attachment to plywood roofs would require the following number of screws noted for various plywood thicknesses:

- 1/2" plywood - 24 #8 screws/20 #10 screws/18 #12 screws
16 #14 screws
- 5/8" plywood - 20 #8 screws/16 #10 screws/14 #12 screws
14 #14 screws
- 3/4" plywood - 16 #8 screws/14 #10 screws/12 #12 screws
10 #14 screws

The noted screw should be long enough to extend through the plywood roof deck and protrude a minimum of 1/4 inch beyond. These values utilize a factor of safety of 2-1/2. The plywood was assumed to be C-D grade with exterior glue (all plies Group 1).

The unit is also intended to be utilized in steel construction and may be attached to metal decking or to steel girts. Attachment to Lightgage Metal framing thicknesses would require the following number of screws for the various thicknesses:

- 20 gage metal - 32 #8 through #14 screws
- 18 gage metal - 22 #8 through #14 screws
- 16 gage metal - 12 #8 through #14 screws

SIDE VIEW

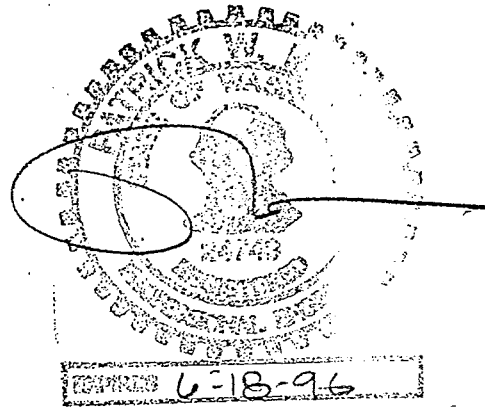
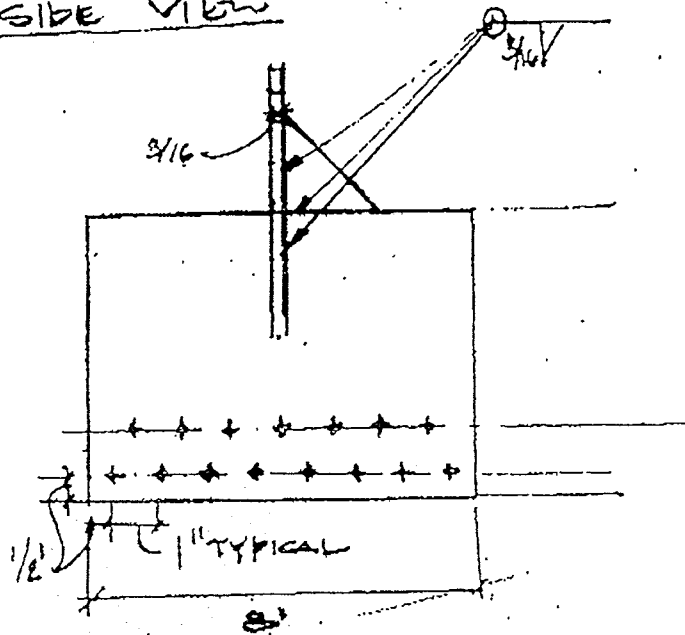

15 SCREWS

CHECK BENDING FEET TO PLATE

$$M = 5000 \times 3.75 = 1.563 \text{ Kft} \cdot \text{lb}$$

$$S = \frac{bd^2}{6} = \frac{4.25 \times 11^2}{6} = .0726 \text{ IN}^3$$

$$f_b = M/S = 18,750 / .0726 = 258 \text{ KSI} \quad \text{TO HIGH USE STRENGTH}$$

M 18750

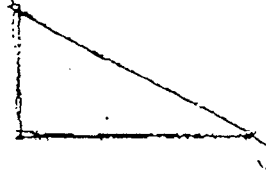

$$S = \frac{bd^2}{6} = \frac{4.25 \times 11^2}{6} = .0726 \text{ IN}^3$$

$$f_b = M/S \quad f_b = 258 \text{ KSI}$$

$$M_{max} = f_b \times S = \frac{258 \times 10^3 \text{ lb}}{1000} \times .0726 \text{ IN}^3 = 290 \text{ IN} \cdot \text{lb}$$

$$d = M/P = \frac{290 \text{ IN} \cdot \text{lb}}{5000} = .058 \text{ IN}$$

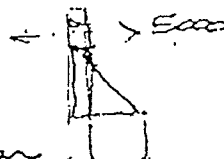

CARRY IN SHEAR

Check Lower Plate for Bendure

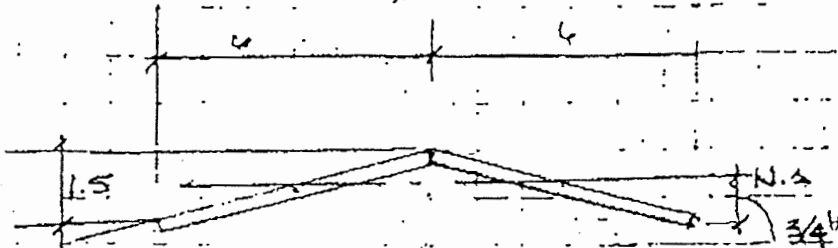

$$I_1 = \frac{bd(b^2 \sin^2 \alpha + d^2 \cos^2 \alpha)}{12}$$

$$A = 1.25 \times 6 = 7.5 \text{ in}^2$$

$$I_2 = \frac{1.25 \times 6 (1.25^2 \sin^2 14 + 6^2 \cos^2 14)}{12}$$

$$\frac{1.25 \times 6 (1.0009 \times 32.9)}{12} = 2.11 \text{ in}^4$$

$$I_0 = 2(2.11) = 4.22$$

$$f_b = \frac{My}{I} = \frac{18750 \text{ in}\cdot\text{lb} \times 0.75 \text{ in}}{4.22 \text{ in}^4} = 3.23 \text{ k/in}^2 < 22$$

PLATE SAFE IN BENDING

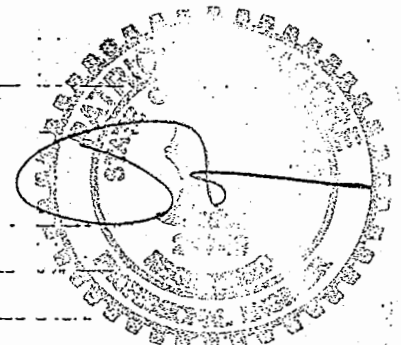

**MATERIALS
TESTING
CORPORATION**

October 9, 1992
Page # 1 of 1
Report # A92021-011

GUARDIAN METAL PRODUCTS
3420 "C" St. N.E., Suite 402
Auburn, WA 98002

Attn: Bud Woodyard

Re: Daily Inspection Summary on 10-8-92
Project: Skyhook
Inspector: Steve Morta

Gentlemen;

As requested an MTC engineer consulted with Guardian Metal Products regarding their fall-restraint/arrest system. It has been proven by photographs that the Skyhook system can resist at least 5400 lbs. in the fall-arrest mode as required by the Federal OSHA requirements. (See report #A92021-010.)

Also there was a question regarding the possible fraying of the steel cable against the edge of the metal Skyhook while in the fall-restraint mode. No visible damage to the steel cable was observed in the photographs or on the cable itself.

A formal engineering report is pending that will update report #A92021-010 dated July 30, 1992, to cover both items above.

If you have any questions concerning the test results, the procedures used, or if MTC can be of any further assistance please call on us at (206) 850-7797.

Respectfully Submitted,
MATERIALS TESTING CORPORATION

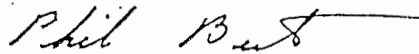

Phil Best
Division Manager

MATERIALS TESTING CORPORATION

July 30, 1992
Page # 1 of 1
Report # A92021-010

GUARDIAN METAL PRODUCTS
3420 "C" St. N.E., Suite 402
Auburn, Washington 98002
(206) 351-2343

Attn: Bud Woodyard and Ron Smith

Re: Skyhook Fall-Arrest and Fall-Restraint Testing
per OSHA and WISHA Requirements

Gentlemen;

On July 27, 1992 an MTC engineer observed and recorded the fall-arrest and fall-restraint capability of Guardian Metal Products' Skyhook roof system. The OSHA and WISHA requirements of 5000 lbs pull for fall-arrest and 3000 lbs pull for fall-restraint were met and in fact exceeded by 67 % for the latter.

An engineering schematic shown in Figure 1 shows the three tests that were performed on the Skyhook system. The first setup tested its ability to withstand a fall-arrest force of 5000 lbs pulling straight down to verify that it could resist a fall by a roofer and his equipment. A come-along with a capability to provide up to 4 tons of load was hooked up in line with a 3/8 in. diameter steel cable. A detailed picture of the hookup is shown in Figures 2 and 3. Fifteen wood screws on each side of the plate held the Skyhook securely in place to the 3/4 in. plywood and 2 x 4 in. stud supports underneath. Attachment 1 provides the engineering analysis for the design of the Skyhook brackets. A calibrated dynamometer capable of reading out to 4 tons measured the applied load directly on a dial gauge readout. A reading of 5000 lbs as required by OSHA is shown in Figure 4.

The second engineering test determined the Skyhook's ability to resist a fall-restraint load of 3000 lbs in tension as shown in the schematic in Figure 1. Two Skyhooks were placed 7 feet apart as shown in Figure 5 with a 3/8 in. steel lanyard attached at each end with 8 in. of play in the line to reduce the tension loads on the hooks. The fall-restraint load was initially taken to the required 3000 lbs and eventually to 5000 lbs with little to no indications of bending or deflection of the Skyhook bracket and no indication of pullout of the wood screws as shown in Figure 6. The Skyhook had a safety factor of 1.67 with respect to OSHA's fall-restraint requirement.

The final test determined the Skyhook's ability to withstand a direct tension load of up to 6000 lbs or a safety factor of 2.0 for fall-restraint. Detailed pictures of the setup are shown in Figure 7 and 8 with a general picture of the setup shown in Figure 9. No indication of pullout or shear of the 30 wood screws were evident. The screws were drilled into 3/4 in. plywood with no additional 2 x 4 in. studs to hold the bracket in place. The 3/16 in. fillet welds held as expected with no indication of cracking. Attachment 2 provides a detailed schematic of the Skyhook's engineering dimensions and capabilities in moment resistance and tension load.

If you have any questions concerning the test results, the procedures used, or if MTC can be of any further assistance please call on us at (206) 850-7797.

Respectfully Submitted,
MATERIALS TESTING CORPORATION

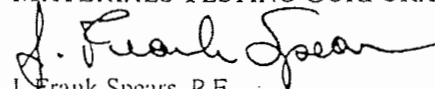
J. Frank Spears, P.E.
V.P./General Manager



Attachment 1: Roof Arrest System dated 6/16/92 (6 pp.)
Attachment 2: Engineering Dimensions (3 pp.)

cc: OSHA and WISHA

EXPIRES 6-30-93